

SUPERPRESSURE

AIR OPERATED DIAPHRAGM-TYPE COMPRESSORS

46-14021-2	TWO STAGE	10K & 30K PSI
46-14023	TWO STAGE	6K & 10K PSI
46-14025-2	SINGLE ENDED	10K PSI
46-14035-2	DOUBLE ENDED	10K PSI
46-14060-2	SINGLE ENDED	30K PSI
46-14065	SINGLE ENDED	6K PSI
46-14067	DOUBLE ENDED	6K PSI
46-14068	TWO STAGE	6K & 30K PSI

This Manual is for:

Compressor Part No. : _____
Sales Order No. : _____
Serial No. : _____
Date Manufactured : _____

NEWPORT SCIENTIFIC, INC

8246-E SANDY COURT

JESSUP, MD 20794

PHONE: 301-498-6700 FAX: 301-490-2313

WEBSITE: www.newport-scientific.com

E-MAIL: sales@newport-scientific.com or technical@newport-scientific.com

CONTENTS

- I. INSPECTION
- II. INTRODUCTION
- III. PRINCIPLES OF OPERATION
- IV. CHARACTERISTICS
 - a. Gas/Liquid Service Conversion
 - b. Ordering Data Check Valves
- V. INSTALLATION & OPERATION
 - a. Installation
 - b. Operation
 - c. Priming Procedure
 - d. Verify Check Valve Operation
- VI. TROUBLESHOOTING
- VII. MAINTENANCE
 - a. Stroke Adjustment Procedures
 - 1. Single Head Compressors
 - 2. Double Head Compressors
 - b. Diaphragm Replacement
 - c. Gas Check Valve Replacement
 - d. Pressure Limiting Device Adjustment
- VIII. RECOMMENDED SPARE PARTS & ½" PISTON ASSEMBLY # 85001000300
- IX. ASSEMBLY DRAWINGS & CAPACITY CURVES – SEE LIST
- X. SPECIFICATIONS

I. INSPECTION

If damage is discovered upon unpacking the equipment, an immediate request should be forwarded to the delivering carrier to perform an inspection and prepare a concealed-damage report. Concurrently, the nature and extent of damage should be reported to Newport Scientific, Inc., giving catalog and serial numbers, so that action may be initiated to replace damaged parts, or instructions issued for the return of the apparatus.

II. INTRODUCTION

The Superpressure Diaphragm-Type Gas Compressors handle fluids of all types with absolute purity. The fluid being compressed comes into contact only with clean, dry, corrosion-resistant metallic surfaces. The compressors are suited for all types of laboratory applications as well as for pilot plant and industrial applications requiring low gas flows. The compressors operate at a 14 to 1 maximum compression ratio and are designed to circulate or boost gas from a low pressure to pressures of 6,000, 10,000, or 30,000 psi. These compressors may be used for testing and calibration of critical devices such as missile system components, etc., where hydrostatic pressure testing and calibration would be difficult or impossible.

These compressors may be easily cleaned. Fluids other than ordinary oil, such as oxygen-compatible fluorinated products, may be used for diaphragm pulsing if required for specific applications. Compressors can be constructed of materials other than those normally supplied for particular corrosion-resistant applications on special order. The compressors when specifically cleaned and serviced, are also used for oxygen service.

These compressors are adaptable to either gas or intermittent liquid service. Changeover from one to the other is accomplished by interchanging a set of intake and exhaust check valves. Single or double ball check valves are available from Newport Scientific, Inc. which enable the compressors to be used for intermittent liquid service.

III. PRINCIPLES OF OPERATION

The plunger of the compression head is reciprocated as in a pump. Oil from the storage bulb is compressed by the plunger, which in turn pulses the diaphragm. The fluid to be compressed is taken in and discharged on the opposite side of the diaphragm through the check valves in the head plate on the down and up stroke of the diaphragm. Oil is drawn into the chamber beneath the diaphragm by the suction created on the plunger backstroke. Excess oil in the chamber can flow back to the storage bulb during the forward plunger stroke through the pressure limiting device. This built-in hydraulic device is manually adjustable and ensures that the discharge pressure of the compressor cannot exceed a preset limit. The plunger stroke is preset so that under normal operating conditions, oil will not flow through the pressure limiting device unless the maximum discharge pressure is exceeded.

IV. CHARACTERISTICS

- Contamination-free gas compression.
- Parts in contact with gas are made of the following materials:
- Upper head plates, 17-4PH SS; Valves, 302, 304, 316, 17-4PH SS and Nylon 101; Diaphragms, 302 SS.
- Compressor is suitable for suction at constant or continually varying suction pressures up to the maximum permissible discharge pressure.
- Compression ratios of up to 14-to-1 are obtainable for each stage.
- Diaphragm life in excess of 500 hours of operation normally attained.
- Absence of stuffing box permits leak-free operation.
- Elastomer packing provides a leak-free oil seal, long life and never needs tightening.
- Interchangeable check valves permit either continuous gas or intermittent liquid service.
- Check valves can be easily removed for cleaning and replacement.
- Floating hydraulic plunger ensures minimum wear on packing.

GAS/LIQUID SERVICE CONVERSION

These compressors can be adapted for intermittent liquid service. To convert from gas to intermittent liquid service or vice-versa, replace the set of intake and exhaust check valves on the compressors with the set specified in Table for the particular service application. On the 6,000 and 10,000 psi gas head, for intermittent service with normal liquids, double-ball check valves must be used. Difficult liquids are water, volatile hydrocarbons, low or high-viscosity liquids and liquids containing sediments. On 30,000 psi gas heads, for intermittent liquid service, double-ball check valves must be used for all liquids.

PRECAUTION

****Liquid service check valves CANNOT be used on Two-Stage Compressors.****

ORDERING DATA AND SPECIFICATIONS FOR CHECK VALVES

COMPRESSOR CATALOG NUMBER	QTY	STANDARD GAS CHECK VALVES INLET/DISCHARGE	LIQUID SERVICE SINGLE BALL INLET/DISCHARGE	LIQUID SERVICE DOUBLE BALL INLET/DISCHARGE
46-14025-2 46-14065	1 Ea	44-11102 44-11107	44-14100 44-14115	44-14210 44-14215
46-14035-2 46-14023 46-14067	2 Ea	44-11102 44-11107	44-14100 44-14115	44-14210 44-14215
46-14060-2	1 Ea	44-13100 44-13120		44-13140 44-13160
46-14021-2 46-14068	1 Ea	44-11102 44-11107 44-13100 44-13120		

*Also used where ultra-pure cleaning is required.

Each check valve listed in Table has a ¼ inch O.D. female tubing opening. Special-Inlet Adapter 45-16705 for liquid service can be used with the 44-13140, 44-14100, and 44-14210 Intake Check Valves when a ¼ inch NPT connection is desired. This adapter converts the ¼ inch O.D. female connection to ¼ inch NPT, female.

V. INSTALLATION & OPERATION

CAUTION

For oxygen service, use HALOCARBON or similar oils to prevent reaction with the oxygen. Thoroughly clean vital areas for oxygen service. The use of a HALOCARBON grease on bolt threads and other hardware is suggested. Recommendations for special applications may be obtained from the SUPERPRESSURE Engineering Dept.

INSTALLATION

1. Remove plug from oil reservoir, remove plugs from inlet and discharge gas check-valves and from air-supply connections.

NOTE

Unit may be bench operated without tie-down bolts. Mounting holes are provided where their use is necessary. Mounting data may be obtained from the detailed drawings.

2. An air-filter pressure-regulator-lubricator (Cat. No. 46-13753) is included as part of the compressor. A dry air source with pressure not to exceed 125 psi is connected to the air filter.
3. Air-exhaust ports exhaust through mufflers to the atmosphere. Where desirable, the exhaust may be vented away from the unit. We recommend a minimum vent-pipe of 3/4-inch to preclude malfunction of air-cycling valve because of backpressure.
4. Fill lubricator to correct level with lubricating oil (SAE 20)* Oil feed rate is factory-set at 2-drops /minute at maximum operating pressure. This oil provides the only lubrication necessary for the air operator.
5. Install a 5- to 10- micron, dry-type filter (Cat. No. 49-14405) in the gas-inlet line between the gas supply and the compressor.
6. Connect gas-suction line (use SUPERPRESSURE Tubing, Cat. No. 45-11020) to port on head marked "IN" on units 46-14021-2, 46-14025-2, 46-14060-2, 46-14023 46-14068 and 46-14065. Connect the gas-suction line to inlet manifold on unit 46-14035-2 and 46-14067.

OPERATION

NOTE

Before turning on the air pressure, turn out (unscrew) the pressure regulator adjustment screw. The unit can be started at the air-shutoff valve (not supplied) in the air-supply line, or by screwing in the adjustment on the pressure regulator. The latter operation is not normally intended for start-stop control, but is used to regulate the maximum pressure to the compressor.

*Newport Scientific, Inc. uses Oildyne Hydraulic Fluid 15-40.

PRECAUTION

If dirt enters the compressor, the diaphragm and check valves may be damaged. It is absolutely essential that the incoming gas is filtered. We suggest a 5 or 10 micron in-line Filter such as Cat. # 49-14405.

Also any lines to be placed between the Filter and the compressor should be thoroughly cleaned. Flush with solvent using a syringe, and blow dry with clean air or gas. (Even a new piece of high pressure tubing may contain sufficient particulate matter to foul the check valves).

To operate the motor-driven compressor, turn on electric power to the compressor. Observe the gas discharge pressure to ensure that the compressor is operating properly. If the compressor fails to build-up pressure, shut off power and perform the "Priming Procedure" in the next paragraph.

PRIMING PROCEDURE

To prime the compressor, perform the following:

1. Close off the gas discharge line.
2. Apply suction pressure to the compressor inlet. (The term suction pressure means the positive pressure applied to the compressor inlet, e.g. a minimum suction pressure of 700 psi is recommended for 10,000 psi discharge on 46-13411-2).
3. Add oil to the reservoir if required.
4. Loosen the stop nut on the top of pressure limiting device, being careful not to lose the setting. Reverse the set screw back until it no longer applies tension to the spring. The stop nut will turn with the set screw, thereby maintaining the original Factory setting.
5. Run the compressor. While it is running, loosen the large gland nut at the base of the pressure limiting device by 1-1/2 turns, and pull back on the body of the limiter to release the orifice piece. This removes all force from the seat and allows fresh oil to be pulled in from the reservoir.

The large gland nut should be loosened just for a couple of strokes of the compressor and then retightened. Some oil will be spilled out during the above operation.

6. Return the setscrew to its' original setting and retighten the stop nut.

PROCEDURE FOR VERIFYING PROPER CHECK VALVE OPERATION

1. Install pressure gauges on Compressor Inlet & Outlet, if not already present.
2. Apply suction pressure of 1,000 psi to Compressor Inlet.
3. Operate Compressor.
4. If either gauge fluctuates wildly then remove check valves and clean or replace.

VI. TROUBLESHOOTING

TROUBLE	PROBABLE CAUSE	CORRECTIVE ACTION
Air Drive Inoperative	<ol style="list-style-type: none"> 1. Low air pressure, or clogged air line filters 2. Improper lubrication 3. Loose or broken connection 4. Malfunction of pilot valves or air-transfer valve 5. Improper stroke adjustment 	<ol style="list-style-type: none"> 1. Check air pressure. Clean air line or filter, install proper size air line or filter, install proper size air line (3/8" pipe min). 2. Check lubricator adjustment. Set to 2 drops min., running free. 3. Tighten or replace. 4. Replace pilot valve, air-transfer valve or both. 5. Refer to Stroke Adjustment.
Pump stalls before pressure develops	<ol style="list-style-type: none"> 1. Insufficient air pressure 2. Air line restriction 3. Improper cylinder lubricator 4. Pressure limiting device locked in 	<ol style="list-style-type: none"> 1. Obtain proper air pressure. 2. Remove restriction. 3. Check lubricator and grade of oil used. Set to 2 drops min. Running free. 4. Back-off pressure limiting device screw.
Pump operative developing less than max.	<ol style="list-style-type: none"> 1. Inlet pressure too low 2. System leakage 3. Air pressure too low 4. Faulty inlet & discharge check valve 	<ol style="list-style-type: none"> 1. Keep compression ratio at 14:1. 2. Isolate pump and check for leaks. 3. Obtain proper air pressure. 4. Check gauges in inlet and discharge line with pump cylinder under normal conditions. If inlet gauge fluctuates radically, replace inlet check valve assembly. If discharge gauge fluctuates radically, replace discharge check valve assembly.

TROUBLE	PROBABLE CAUSE	CORRECTIVE ACTION
Pump operative developing less than max. pressure	5.Pump not primed.	5.Refer to priming procedure.
	6.Defective hydraulic check valve or pressure limiting device	6.Replace faulty valve or device. Observe oil reservoir for check valve action.
	7.Improper stroke adjustment	7.Refer to Stroke Adjustment.
Pump developing maximum pressure, output volume incorrect	1.External leaks on check valve and diaphragm (check by bubble testing)	1.Tighten or replace as necessary.
	2.Oil pressure limiter set too low. Oil level in oil reservoir will move up & down with each stroke.	2.Increase by turning IN adjustment screw to 6,600 psi, 11,000 psi, or 32,000 psi, depending on type of compressor. <u>DO NOT</u> adjust this device unless necessary.
	3.Malfuction in inlet and discharge check valves.	3.See above.
	4.Low input pressure	4.Check for proper compensation ratio.
	5.Ruptured diaphragm(s)	5.Replace with new diaphragm(s).
	6.Improper stroke adjustment	6.Refer to Stroke Adjustment.

VII. MAINTENANCE

STROKE ADJUSTMENT PROCEDURES

Pivot-valve assembly is located on threaded supports and a plate. The plate has elongated holes to allow the pivot valves to slide either toward or away from the cam for fine-stroke adjustments. The stroke setting at the pivot-valve assembly is made at the factory and should not normally require changing; however, if it becomes necessary to change or reset, proceed as follows:

SINGLE-HEAD COMPRESSORS

1. Position the ball valve so that the space between the bottom face of the mounting plate and the upper face of the spacer is approximately 1-1/16". Lock in place. (See Compressor Assembly Drawing)
2. Loosen the two hex-head screws holding the ball valves to the mounting plate. Slide both ball valves inward toward the plunger. Tighten both screws to hold valves in place.
3. Start compressor with no gas pressure. Operate very slowly.
4. Block the exhaust port of the upper ball valve with a finger and let the plunger go to the very bottom of the bore. Keep finger in place.

5. With inside calipers measuring the distance between the face of the body (not the packing nut) and the face of the coupling.
6. Remove finger from the ball valve exhaust. The plunger will return. Let the compressor continue to run slowly.
7. Increase the calipers measurement $1/16$ "; i.e., if the measurement was $5/16$ ", increase to $3/8$ ".
8. Loosen screws slightly on ball valves. Insert calipers between body face and coupling.
9. Slide both ball valves out until the coupling touches the calipers while compressor is running. This must be done in very small increments.
10. Tighten the screws on the ball valves and again measure stroke.
11. Allow compressor to run for several minutes and observe the oil reservoir bowl. If it appears that the oil level is rising and falling with each stroke, or if the pressure limiting device is set for too low a pressure, refer to paragraph setting pressure limiting device.
12. To shorten the stroke, break the screws and very tightly tap the ball valves in. Tighten screws.
13. Repeat steps 11 and 12, above, until the oil level remains steady.

CAUTION

The pressure limiting device should never heat during operation.

DOUBLE-HEAD COMPRESSORS

1. Position the ball valve so that the space between the bottom face of the mounting plate and the upper face of the spacer is approximately $1-1/16$ ". Lock in place. (See Compressor Assembly Drawing).
2. Break the two hex-head screws holding the ball valves to the mounting plate. Slide both ball valves in toward the plunger. Tighten both screws to hold valves in place.

Perform steps 1 and 2 on both ends before starting compressor.
4. Start the compressor with no gas pressure.
5. Block the exhaust port of the upper ball valve with a finger and let the plunger go to the very bottom of the bore.
6. Using inside calipers, measure the distance between the face of the body (not the packing nut) and the face of the coupling.

7. Remove finger from the ball valve exhaust. The plunger will return. Let the compressor continue to run slowly.
8. Open the calipers 1/16"; i.e., if the measurement was 5/16", increase to 3/8".
9. Loosen screws slightly on ball valves. Insert calipers between body face and coupling.
10. Slide both ball valves out until the coupling touches the calipers while compressor is running. This must be done in very small increments.
11. Tighten the screws on the ball valves and measure the stroke again.
12. Repeat steps 2 through 8 for the other ball valve.
13. Repeat steps 11, 12, and 13 above.

REPLACING DIAPHRAGM

1. Shut down unit, closing off gas inlet and discharge lines.
2. Crack connections to gas check valves to allow trapped pressure to escape.
3. Remove all gas connections.
4. Secure hydraulic section in some form of clamping device.
5. Remove head bolts, remove head, and inspect. Inspect valves, clean and cover with clean cloth.
6. Remove diaphragm.

NOTE

The 6,000 and 10,000 psi units have one diaphragm per head; the 30,000 psi units have two diaphragms per head.

7. Remove preservative from new diaphragm(s) thoroughly clean and put new diaphragm(s) in place.
8. Install head connections by reversing removal procedures. (Use check valve as guide for proper relocation).

NOTE

Lubricate washer and bolt threads with bearing grease for normal operation; use HALOCARBON grease for oxygen services.

9. Hand tighten all head bolts. Then sequentially tighten opposing bolts with torque wrench in equal increments of 10 ft-lbs until final tightness. (Torque to approximately 150 ft-lbs for 6,000 and 10,000 psi Head and 350 ft-lbs for 30,000 psi Head)
10. Attach all gas connections.
11. Prime the compressor as described in Priming Instructions.

GAS CHECK VALVE REPLACEMENT

1. Shut down unit as previously described.
2. Remove gas connections as previously described.
3. Remove check valves and examine for wear or damage.
4. Replace seat assembly in check valves if required.
5. If check valves are of the single ball or double ball type, it is recommended that they be completely replaced if found defective.

ADJUSTMENT OF PRESSURE LIMITING DEVICE

NOTE

The Pressure Limiting Device was preset by Newport Scientific and should never need re-adjustment. This device was set to release oil back to the storage bulb when the discharge pressure reached 110% of the maximum pressure rating of the compressor. This setting was obtained by turning the set screw at the top of the pressure limiter until the desired release pressure was obtained.

The set screw was then held stationary while the outer stop nut was tightened down to the limiter body to lock in the setting. As long as the stop nut is not turned relative to the set screw, the set screw can be turned out and in for priming and still maintain the original factory setting.

If the stop nut has been turned relative to the set screw, the following procedure can be followed to reproduce the original setting.

1. Install pressure gauges in the inlet & outlet lines of the compressor if not already present.
2. Make sure the system is primed by performing the **Priming Procedure**.
3. Make sure check valves are operating properly according to the **Procedure for Verifying Proper Check Valve Operation**.
4. Stop compressor operation.

5. Loosen outer stop nut on top of pressure limiter and turn set crew back until all tension is removed from the spring.
6. Apply suction pressure of at least 1000 psi.
7. Adjust set screw slowly inward to obtain the following maximum discharge pressure -
 - for 6,000 psi compressors, set to 6,600 psi
 - for 10,000 psi compressors, set to 11,000 psi
 - for 30,000 psi compressors, set to 33,000 psi

NOTE

For a two stage compressor, set up to 5,000 psi on first stage.

NOTE

Outlet pressure gauge needle will fluctuate slightly with each piston stroke, use the highest reading on each stroke when setting the pressure.

8. Hold set screw stationary and tighten outer stop nut to lock in pressure setting.

NOTE

It is not recommended that the pressure limiter be set at a pressure lower than the original factory setting.

VIII. RECOMMENDED SPARE PARTS

DESCRIPTION	CAT. NO OR PART NO.	46- 14025-2	46- 14060-2	46- 14035-2	46- 14021-2	46- 14023	46- 14068	46- 14065	46- 14067
CHECK VALVE, HYDRAULIC	44-14110	1	1	2	2	2	2	1	2
CHECK VALVE, INTAKE	44-11102	1		2	1	2	1	1	2
CHECK VALVE, DISCHARGE	44-11107	1		2	1	2	1	1	2
CHECK VALVE, INTAKE	44-13100		1		1		1		
CHECK VALVE, DISCHARGE	44-13120		1		1		1		
DIAPHRAGM	62018000500	1	2	2	3	1	2		
DIAPHRAGM	84001001100					1	1	1	2
OILER	P1004002900	1	1	2	2	2	2	1	2
SOFTGOOD PACKING KIT	85001000900	1		2	1	1			
SOFTGOOD PACKING KIT	85001000500		1		1		1		
SOFTGOOD PACKING KIT	85001001100					1	1	1	2
PACKING RETAINER	64042002500	1		2	1	1	1		
PACKING RETAINER	65013002700		1		1				
PACKING RETAINER	84001000800					1	1	1	2
PACKING FOLLOWER	64042002200	1		2	1	1	1		
PACKING FOLLOWER	65013002800		1		1				
PACKING FOLLOWER	84001000700					1	1	1	2

PART NO. 85001000300 – ½" PISTON ASSEMBLY (CHEVRON PACKINGS TO POLYPACK)
Please Call Newport Scientific, Inc. for further information on this part.

IX. ASSEMBLY DRAWINGS

COMPRESSOR # 46-14021-2 AIR OPERATED TWO STAGE 10 & 30K PSI

46-14021-2	Compressor Assembly Sheet 1 & 2
62037002802	Head Assembly 10,000 PSI
63034001802	Head Assembly 30,000 PSI
44-11102	Intake Check Valve 10,000 PSI
44-11107	Discharge Check Valve 10,000 PSI
44-13100	Intake Check Valve 30,000 PSI
44-13120	Discharge Check Valve 30,000 PSI
44-14110	Inlet Check Valve Single Ball
62006001200	Assembly Relief Valve-Liquid Service
77053000900	Air Drive Double End
Curve 10 & 30K Air	Capacity Curve

COMPRESSOR # 46-14023 AIR OPERATED TWO STAGE 6 & 10K PSI

46-14023	Compressor Assembly Sheet 1 & 2
62037002902	Head Assembly 10,000 PSI
84001001500	Head Assembly 6,000 PSI
44-11102	Intake Check Valve 10,000 PSI
44-11107	Discharge Check Valve 10,000 PSI
44-14110	Inlet Check Valve Single Ball
62006001200	Assembly Relief Valve-Liquid Service
77053000900	Air Drive Double End
Curve 6 & 10K Air	Capacity Curve

COMPRESSOR # 46-14025-2 AIR OPERATED SINGLE ENDED 10K PSI

46-14025-2	Compressor Assembly Sheet 1 & 2
62028003002	Head & Body Assembly 10,000 PSI
44-11102	Intake Check Valve 10,000 PSI
44-11107	Discharge Check Valve 10,000 PSI
44-14110	Inlet Check Valve Single Ball
62006001200	Assembly Relief Valve-Liquid Service
77053001000	Air Drive Single End
Curve 10K SE DE Air	Capacity Curve

COMPRESSOR # 46-14035-2 AIR OPERATED DOUBLE ENDED 10K PSI

46-14035-2	Compressor Assembly Sheet 1 & 2
62037002802	Head Assembly Left Side 10,000 PSI
62037002902	Head Assembly Right Side 10,000 PSI
44-11102	Intake Check Valve 10,000 PSI
44-11107	Discharge Check Valve 10,000 PSI
44-14110	Inlet Check Valve Single Ball
62006001200	Assembly Relief Valve-Liquid Service
77053000900	Air Drive Double End
Curve 10K SE DE Air	Capacity Curve

COMPRESSOR # 46-14060-2 AIR OPERATED SINGLE ENDED 30K PSI

46-14060-2	Compressor Assembly Sheet 1 & 2
63035000902	Head Assembly 30,000 PSI
44-13100	Intake Check Valve 30,000 PSI
44-13120	Discharge Check Valve 30,000 PSI
44-14110	Inlet Check Valve Single Ball
62006001200	Assembly Relief Valve-Liquid Service
77053001000	Air Drive Single End
Curve 30K SE Air	Capacity Curve

COMPRESSOR # 46-14065 AIR OPERATED SINGLE END 6K PSI

46-14065	Compressor Assembly Sheet 1 & 2
85005000100	Head Assembly 6,000 PSI
44-11102	Intake Check Valve 10,000 PSI
44-11107	Discharge Check Valve 10,000 PSI
44-14110	Inlet Check Valve Single Ball
62006001200	Assembly Relief Valve-Liquid Service
77053001000	Air Drive Single End
Curve 6 & 30K Air	Capacity Curve

COMPRESSOR # 46-14067 AIR OPERATED DOUBLED END 6K PSI

46-14067	Compressor Assembly 1 & 2
84001001500	Head Assembly 6,000 PSI Right Side
85005000100	Head Assembly 6,000 PSI Left Side
44-11102	Intake Check Valve 10,000 PSI
44-11107	Discharge Check Valve 10,000 PSI
44-14110	Inlet Check Valve Single Ball
62006001200	Assembly Relief Valve-Liquid Service
77053000900	Air Drive Double End
Curve 6K Air	Capacity Curve

COMPRESSOR # 46-14068 AIR OPERATED TWO STAGE 6 & 30K PSI

46-14068	Compressor Assembly Sheet 1 & 2
84001000300	Head Assembly 6,000 PSI
63034001802	Head Assembly 30,000 PSI
44-11102	Intake Check Valve 10,000 PSI
44-11107	Discharge Check Valve 10,000 PSI
44-13100	Intake Check Valve 30,000 PSI
44-13120	Discharge Check Valve 30,000 PSI
44-14110	Inlet Check Valve Single Ball
62006001200	Assembly Relief Valve-Liquid Service
77053000900	Air Drive Double End
Curve 6 & 30K Air	Capacity Curve

X. SPECIFICATIONS

AIR OPERATED DIAPHRAGM COMPRESSOR SPECIFICATIONS CHART

ITEM	46-14025-2 (SINGLE END 10K)	46-14035-2 (DOUBLE END 10K)	46-14060-2 (SINGLE END 30K)	46-14021-2 (TWO STAGE 10, 30K)	46-14023 (TWO STAGE 6,10K)	46-14068 (TWO STAGE 6,30K)	46-14065 (SINGLE END 6K)	46-14067 (DOUBLE END 6K)
Max. Discharge Pressure	10,000PSI	30,000PSI	30,000PSI	10,000PSI	10,000PSI	30,000PSI	6,000PSI	6,000PSI
Max. Inlet Pressure	Up to Discharge	Up to Discharge	Up to 10,000 psi	Up to 10,000 psi	Up to 6,000PSI	Up to Discharge	Up to Discharge	Up to Discharge
Recommended Compression Ratio	14 to 1							
Min. Gas Suction Pressure	700	2000	350	150	400			
Number of Stages	1			2	1			
Max. Air-Drive Pressure	125 psi							
Min. Air-Drive Pressure (for max. rating)	80 psi							
Mounting Position	Vertical	Horizontal	Vertical	Horizontal	Horizontal	Vertical	Vertical	Horizontal
Air Consumption	20 SCFM	25 SCFM	40 SCFM	45 SCFM	25 SCFM	40 SCFM	25 SCFM	40 SCFM
DIMENSIONS								
Length	12"	30"	12"	32"	30"	32"	12"	30"
Width	14"	13"	14"	13"	13"	13"	14"	13"
Height	17"	16"	19"	16"	16"	16"		16"

ITEM	46-14025-2 (SINGLE END 10K)	46-14035-2 (DOUBLE END 10K)	46-14060-2 (SINGLE END 30K)	46-14021-2 (TWO STAGE 10, 30K)	46-14023 (TWO STAGE 6, 10K)	46-14068 (TWO STAGE 6,10K)	46-14065 (SINGLE END 6K)	46-14067 (DOUBLE END 6K)
PORTS								
Drive Air Inlet and Exhaust	3/8" NPT FEMALE							
Gas Inlet & Discharge	1/4" AMINCO							
Recommended Drive-Air Line Size	3/8" PIPE, MINIMUM							
Estimated Weight	70 lbs. net 100 lbs.ship	130 lbs. net 180 lbs.ship	70 lbs. net 100 lbs.ship	130 lbs. net 180 lbs.ship	130 lbs. net 180 lbs.ship	130 lbs. Net 180 lbs.ship	70lbs. Net 100lbs. ship	130 lbs.net 180 lbs.ship
Mounting	4 mounting holes 17/32" dia. on 8- inch center	4 mounting holes 1/2-13 UNC-2B thread, 1/2" deep on 4-5/8" centers by 6-inch center 4 mounting holes 17/32" dia. on 8-inch center	4 mounting holes 1/2-13 UNC-2B thread, 1/2" deep on 4-5/8" centers by 6-inch center	4 mounting holes 1/2-13 UNC-2B thread, 1/2" deep on 4-5/8" center by 6-inch center	4 mounting holes 1/2-13 UNC-2B thread, 1/2" deep on 4-5/8" center by 6-inch center	4 mounting holes 1/2- 13 UNC-2B thread 1/2" deep on 4 5/8" center by 6" center	4 mounting holes 17/32" dia. on 8" thread	4 mounting holes 1/2- 13 UNC-2B thread 1/2" deep on 4 5/8" center by 6" center
Volumetric Displacemet per Stroke	0.13 cu. in. 2.15 cc	0.26 in ³ 4.30 cc	0.0785 in ³ 1.25 cc	1 st stage 0.13 in ³ 2.15 cc 2 nd stage .0785 in ³ 1.25 cc	1 st stage .36 in ³ 5.90 cc 2 nd stage 0.13 in ³ 2.15 cc	1 st stage 0.36 in ³ 5.90 cc 2 nd stage 0.0785 in ³ 1.25 cc	0.36 in ³ 5.90 cc	0.72 in ³ 11.80 cc
Speed (max. at free flow)	130 Strokes/Min.							
Stroke	1							
Length (max. under pressure)	3/4" PIPE MINIMUM, 10FT. MAXIMUM							
Exhaust Air Vent (if required)	3/4" PIPE MINIMUM, 10FT. MAXIMUM							
Oil for Air Lubricator	**SAE 20**							
Oil for Hydraulic Head	NORMAL, SAE 20**, HALOCARBON OIL FOR OXYGEN SERVICE							

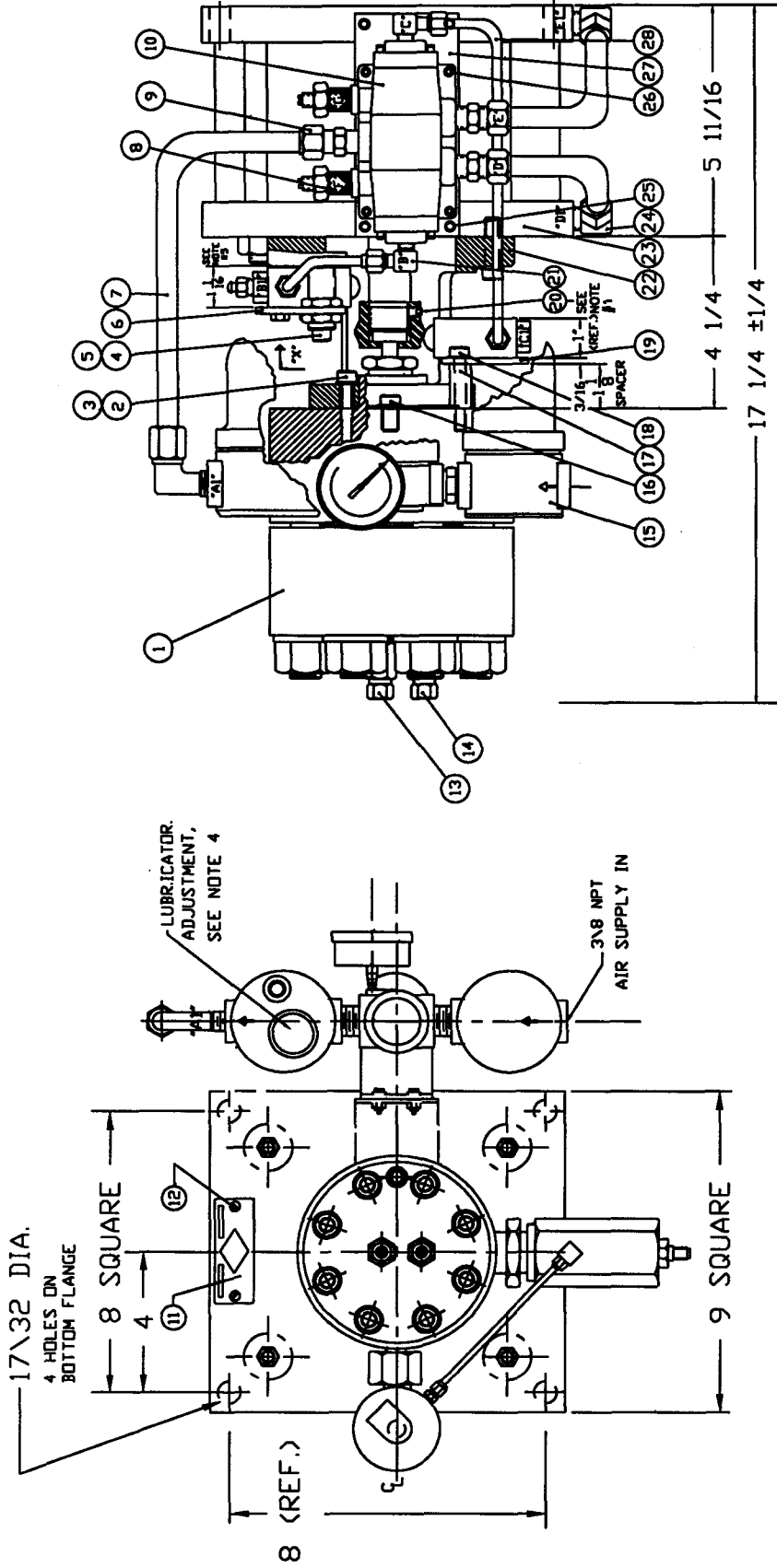

NOTE:

1. USE ONE (1) SET SCREW ONLY, NEAREST TO FLAT ON SHAFT. HOLD END PLAY OF SHAFT TO A MINIMUM.
2. INSTALL FILTER, REGULATOR AND LUBRICATOR, USE BOLT ITEM 16.
3. LOW PRESSURE PNEUMATIC HOOK-UP:
 "A" MAIN AIR SUPPLY (INLET) CONNECT TO "AI".
 "B" LOW PRESSURE TRANSFER, CONNECT TO PILOT VALVE "BI".
 "C" LOW PRESSURE TRANSFER, CONNECT TO PILOT VALVE "CI".
 "D" AIR SUPPLY TO LEFT SIDE OF PISTON, CONNECT TO PORT "DI".
 "E" AIR SUPPLY TO RIGHT SIDE OF PISTON, CONNECT TO PORT "EI".
 "F" EXHAUST FROM PORT D1 THROUGH MUFFLER AND ATMOSPHERE.
 "G" EXHAUST FROM PORT E1 THROUGH MUFFLER AND ATMOSPHERE.
4. ADJUST LUBRICATOR FOR 2 DROPS OF OIL PER MINUTE.
5. REFER TO PARAGRAPH "B" STROKE ADJUSTMENT PROCEDURES OF INSTRUCTION MANUAL 865.
6. FOR SECTION X-X, SEE DWG. D46-14060-2, SHEET 2 OF 2.

UNLESS OTHERWISE SPECIFIED

DIMENSIONS ARE IN INCHES

TOLERANCES:

FRACTIONS ± REF

DECIMALS ± ONLY

ANGLES ±

REMOVE ALL BURRS AND SHARP EDGES

DO NOT SCALE THIS DRAWING

FINISH:

BY NAME DATE

PREPARED

CHECKED P. ZIEG 7-30-08

ENGR/ISSN

APPROVED

MATERIAL SEE M.V. D46-14060-2

SHEET 2

SCALE

WEIGHT

SHEET 1 OF 2

PROPRIETARY

This document is issued in strict confidence on condition that it is not copied, reprinted, or disclosed to a third party, wholly or in part, without written consent of Newport Scientific Inc.



30,000 PSI PNEUMATIC OPERATED DIAPHRAGM COMPRESSOR ASSY. SINGLE ACTING 3/8 DIA. PISTON GAS SER.

PART NO. 46-14060-2

DRAWING NO. 46140602

ITEM	QTY.	DESCRIPTION	PART NO.	MATERIAL
26	—	TUBE 1/4 O.D.	P1245000100	COPPER
27	1	BRACKET, VALVE MOUNTING	77053002000	STEEL
26	4	SCREW, 8-32 UNC-2A, SOC.HD,CAPX3/8LG	04650022220	STEEL
25	4	SCREW, 10-32 UNC-2A,PAN HEAD X3/8LG	02250012620	STEEL
24	2	ELBOW, 3/8 NPT. X 1/2" TUBE, COMP.	P0215012500	BRASS
23	1	DRIVE UNIT	77053001000	ALUM
22	1	SPACER,	62050002100	AL. ALLOY
21	2	ELBOW, 1/8 NPT. X 1/4 O.D. TUBE COMP.	P0215023100	BRASS
20	1	SCREW, SET 1/4-28 UNF-2A X 1/4 LG	02830023211	STEEL
19	1	PILOT VALVE - ASSEMBLY	C13-63005	PER DETAILS
18	2	SCREW, 3/16-18UNC-2A,SOC.HD,CAP X 1 3/4 LG	04650023538	STEEL
17	2	SPACER, TUBE	63035002500	STEEL
16	1	SCREW,5/16-18UNC-2A,SOC.HD,CAPX3/8LG	04650023520	STEEL
15	1	FILTER, REGULATOR, LUBRICATOR, & BRACKET, ASSEMBLY	62050002400	PER DETAILS
14	1	CHECK VALVE — INTAKE	44-13100	PER DETAILS
13	1	CHECK VALVE — EXHAUST	44-13120	PER DETAILS
12	2	SCREW, R2 TAPPING PAN TYPE 8-11/4LG	02240031111	STEEL
11	1	NAME PLATE	63070005300	
10	1	VALVE, 4-WAY MASTER	72020022300	PER DETAILS
9	3	CONNECTOR 3/8 NPT. X 1/8 TUBE,COMP.	P0215104100	BRASS
8	2	MUFFLER, 3/8 NPT.	62020004000	AL. & BRONZE
7	—	TUBE, 1/2 O.D.	P1245000200	COPPER
6	1	PILOT VALVE ASSEMBLY	63035001400	PER DETAILS
5	2	SPLIT LOCK WASHER 3/16 I.D.	R1061005300	STEEL
4	2	SCREW, 5/16 - 18 UNC - 2A, SOC. HD. CAP. X 2 3/4 LG.	04650023548	STEEL
3	6	SCREW, 5/16 - 18 UNC - 2A, SOC. HD. CAP. X 1 1/2 LG.	04650023530	STEEL
2	9	WASHER, FLAT 3/16 I.D.	63167001200	STEEL
1	1	3/8 DIA PISTON HEAD ASSEMBLY	63035000902	PER DETAILS

LIST OF MATERIAL

UNLESS OTHERWISE SPECIFIED DIMENSIONS ARE IN INCHES TOLERANCES: FRACTIONS ± DECIMALS ± ANGLES ± 0°-30'

REMOVE ALL BURRS AND SHARP EDGES DO NOT SCALE THIS DRAWING

BY: NAME DATE FINISH:

CHECKED: P. ZIEG 7-29-08 TITLE 30,000 PSI. PNEUMATIC OPERATED DIAPHRAGM COMPRESSOR ASSEMBLY SINGLE ACTING 3/8 DIA. PISTON GAS SERVICE

ENGR/DRSH APPROVED

INTERNAL CODE DEPT. NO. 59505 SIZE D DRAWING NO. 46-14060-2 PART NO. 46-14060-2

AS NOTED SCALE 1:1 WEIGHT SHEET 2 OF 2

PROPRIETARY
This document is issued in strict confidence on condition that it is not to be reproduced, copied, or otherwise used in any way without the written consent of Newport Scientific Inc.

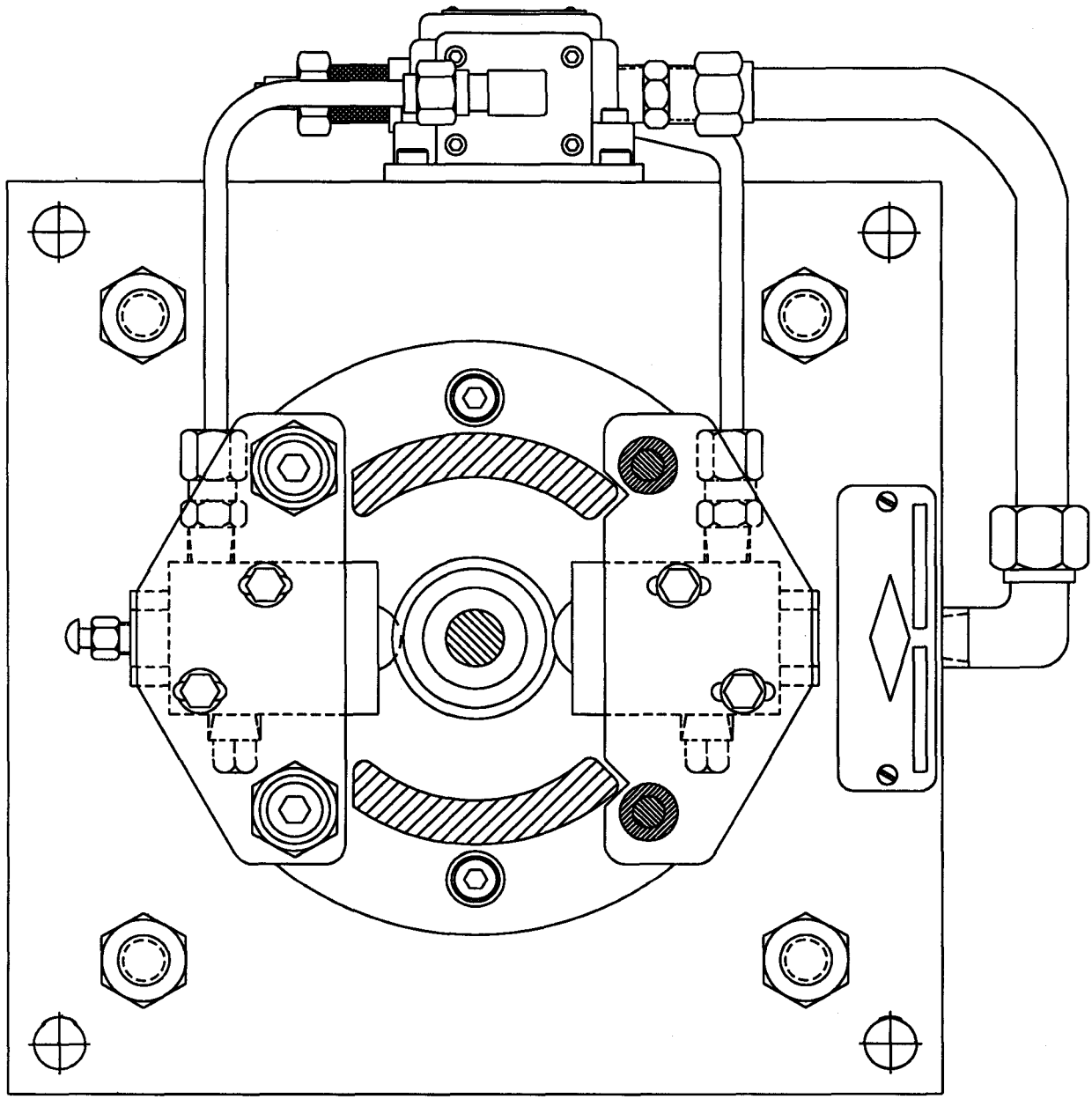

SECTION X-X
SEE SHEET 1 OF 2

REVISIONS		
SYM	DESCRIPTION	DATE
Ⓐ	ITEM #10 WAS B25-65013 ITEM #12 WAS B26-65013 PER ECD #18630	7-12-85
Ⓑ	ITEM #1 WAS P1636-164 ITEM #23 WAS 216-251 PER ECD #18635	7-29-85

ITEM No.	DESCRIPTION	QTY	PART No.	MATERIAL
24	RELIEF VALVE	1	C 12-62006-2	AS PER DETAILS
23	90° ELBOW, COMPRESSION 1/8 NPTM x 1/4 O.D. TUBING TUBING, 1/4 O.D. 6" LONG. APPROX.	1	P219-251	BRASS
22	MALE CONNECTOR, COMPRESSION 1/4 NPT x 1/4 O.D. TUBING	1	P216-525	BRASS
21	OILER "TRICO" TYPE PC #40081	1	P1004-029	BRASS
20	STREET TEE, 1/4 NPTF x 1/4 NPTMALE RUN	1	P204-601	BRASS
19	90° STREET ELBOW, 1/4 NPTM x 1/4 NPTF	1	P201-041	BRASS
18	CHECK VALVE, INTAKE (OIL SIDE)	1	B 44-1410	AS PER DETAILS
17	"O" RING (2-227)	1	P1604-239	BUNA "N"
16	COUPLING	1	B 18-62028	STEEL
15	PISTON 3/8 DIA.	1	B 2-59061	TYPE 440 C. ST. ST.
14	NUT, GLAND RETAINER	1	A 4-59061	TYPE 416 ST. ST.
13	PACKING FOLLOWER	1	B 28-65013	AMPCO #15
12	POLYPAK SEAL PACKING	1	P1615-091	MOLYTHANE
11	PACKING RETAINER	1	B 27-65013	AMPCO #15
10	PARABAK - BACK-UP RING	1	P1604-1099	BUNA "N"
9	"O" RING (2-208)	1	P1604-1061	BUNA "N"
8	DIAPHRAGM	1	D 14-64042-2	ELASTUF. A2
7	"O" RING (2-230)	1	A 5-62018	TYPE 302 ST. ST.
6	STUDS, 3/4-16UNF-2A	1	P1604-820	BUNA "N"
5	HEAD	1	B 14-63034	STEEL
4	WASHER, FLAT	1	D 17-63034	TYPE 17-4 PH. S.S.
3	NUT, HEX. 3/4-16UNF-2B	1	A 11-63034	STEEL
2		1	P1636-165	STEEL
1		1		

LIST OF MATERIAL

NOTE:

- 1 - REPLACED D9-63035.
- 2 - MARK OR TAG WITH ASSEMBLY NUMBER.

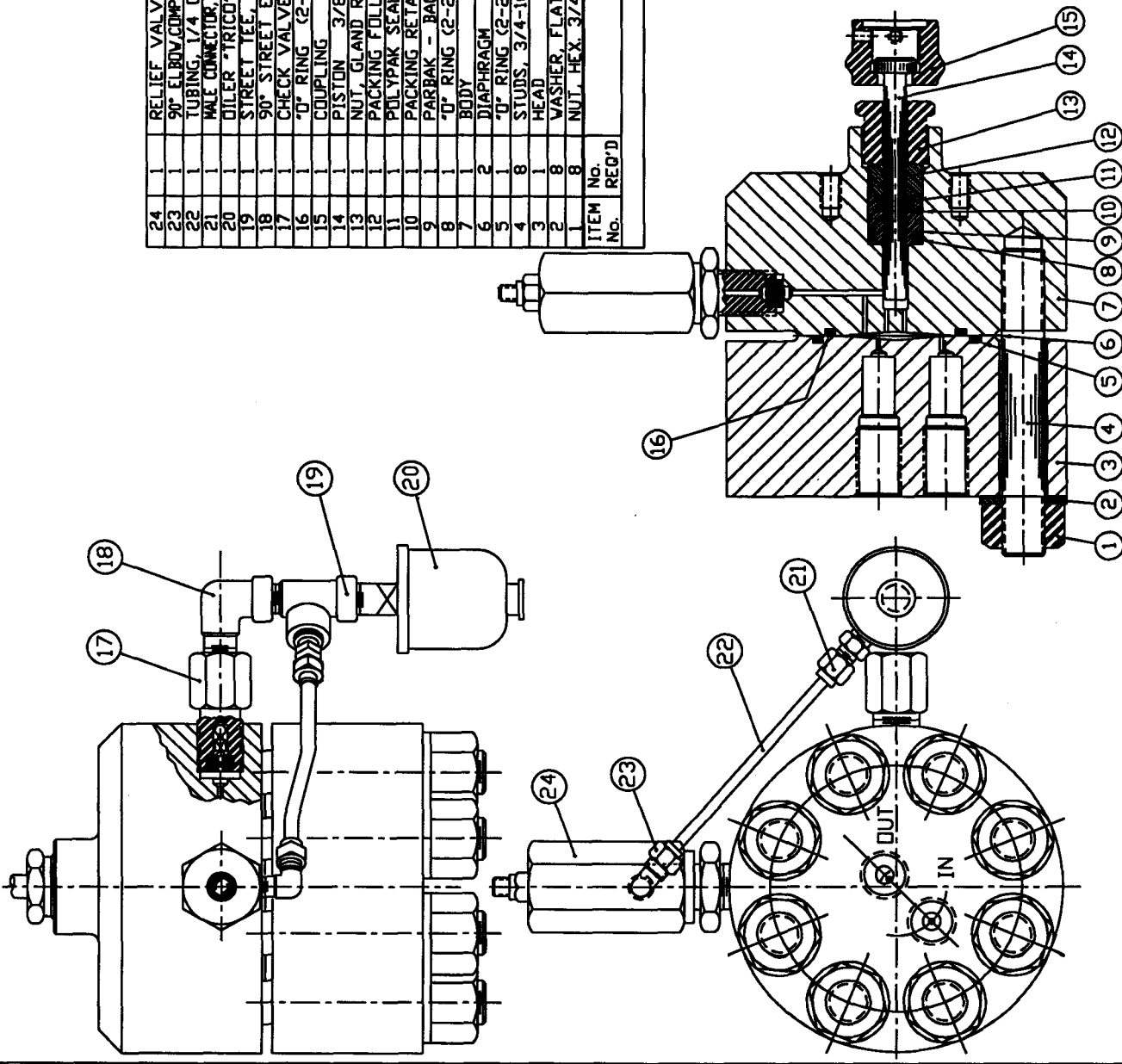

PROPRIETARY
This document is issued in strict confidence on condition that it is not copied, reprinted, or disclosed to a third party, wholly or in part, without written consent of Newport Scientific Inc.

NEWPORT SCIENTIFIC INC.
SUPERPRESSURE

UNLESS OTHERWISE SPECIFIED DIMENSIONS ARE IN INCHES TOLERANCES:
FRACTIONS ±
DECIMALS ±
ANGLES ±0 -30°
REMOVE ALL BURRS AND SHARP EDGES
DO NOT SCALE THIS DRAWING

BY	NAME	DATE	FINISH:
PREPARED			
CHECKED			
EXPRESSION			
APPROVED			

TITLE: 30,000 PSI. PNEUMATIC OPERATED DIAPHRAGM COMPRESSOR, SINGLE ACTING - HEAD ASSEMBLY. 3/8 DIA. PISTON

CODE DEPT. NO. 59505 SIZE D PART NO. 63035000902 DRAWING NO. 9630352 SCALE NONE WEIGHT SHEET 1 OF 1

MATERIAL	D46-14060-2
NEXT ASSY	USED IN
APPLICATION	

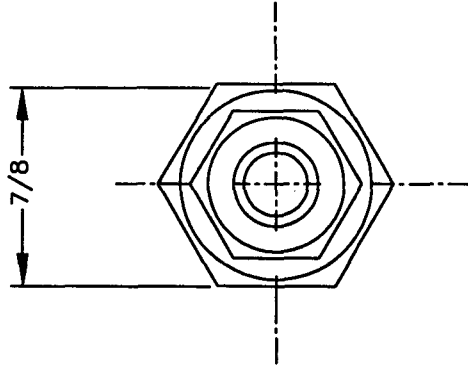
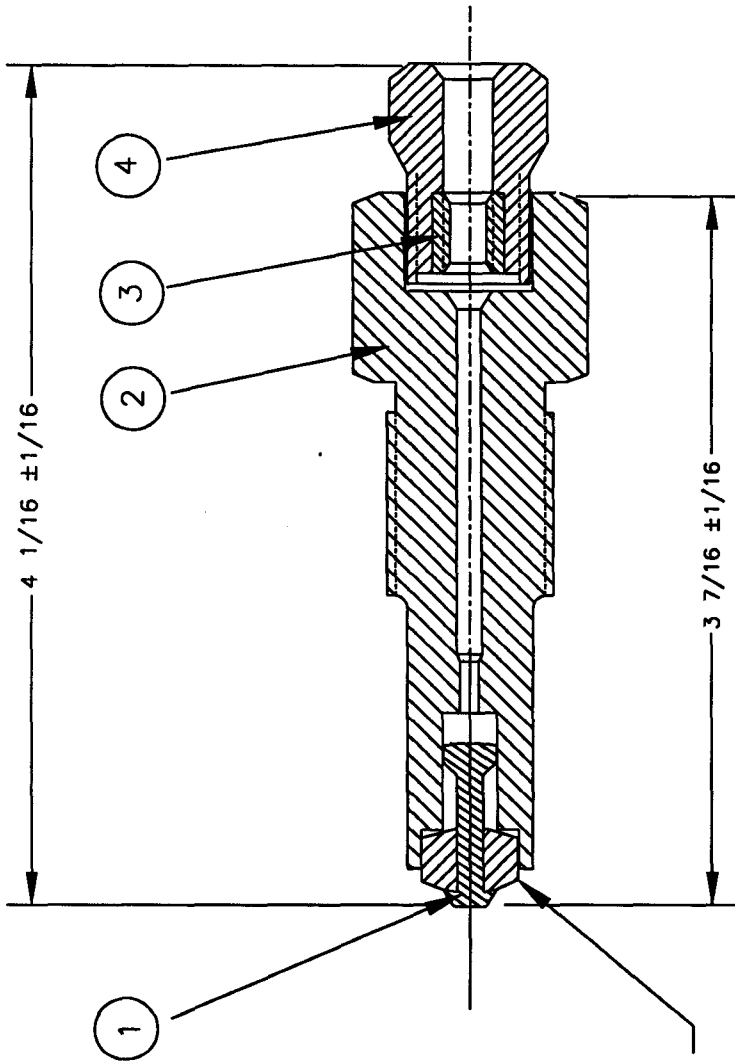

SEE NOTE 1

NOTES:

1. STAKE LENS RING OF POPPET; SUB-ASSEMBLY ITEM 1
IN PLACE WITH CENTER PUNCH IF NECESSARY.
2. TIGHTEN GLAND NUT ITEM 4 HAND TIGHT FOR SHIPPING.
3. TIGHTEN GLAND NUT ITEM 4 TO A TORQUE OF 15 FT./LBS.
APPROX. WITH TUBING INSTALLED.

4. ELECTRO ETCH:

- A. SUPERPRESSURE DIAMOND
- B. CAT NO.
- C. PRESSURE RATING (IF APPLICABLE)
- D. LOT NO. (IF APPLICABLE)
- E. D.O.M.
- F. FLOW ARROW (IF APPLICABLE)

LIST OF MATERIAL			
ITEM	QTY.	DESCRIPTION	MATERIAL
1	1	POPET; SUB-ASSEMBLY	AS PER DETAIL
2	1	VALVE BODY	TYPE 316 ST. STL.
3	1	INNER SLEEVE	TYPE 416 ST. STL.
4	1	GLAND NUT	TYPE 416 ST. STL.

D2-63052	USED ON
NEXT ASSY	APPLICATION
PROPRIETARY	
This document is issued in strict confidence on condition that it is not copied, reprinted, or disclosed to a third party, wholly or in part, without written consent of Newport Scientific Inc.	
UNLESS OTHERWISE SPECIFIED DIMENSIONS ARE IN INCHES TOLERANCES:	
FRACTIONS ±	
DECIMALS ±	
ANGLES ±	
REMOVE ALL BURRS AND SHARP EDGES	
DO NOT SCALE THIS DRAWING	
BY	FINISH:
PREPARED	NAME
CHECKED	DATE
ENGR/DRSH	
APPROVED	
UNLESS OTHERWISE SPECIFIED DIMENSIONS ARE IN INCHES TOLERANCES:	TITLE
FRACTIONS ±	GAS SERVICE
DECIMALS ±	CHECK VALVE 30,000 PSI INTAKE
ANGLES ±	HARD SEAT
REMOVE ALL BURRS AND SHARP EDGES	CODE IDENT. NO.
DO NOT SCALE THIS DRAWING	59505
BY	SIZE
PREPARED	PART NO. 4.4-13100
CHECKED	DRAWING NO. 4413100
ENGR/DRSH	SCALE
APPROVED	WEIGHT
UNLESS OTHERWISE SPECIFIED DIMENSIONS ARE IN INCHES TOLERANCES:	SHEET 1 OF 1
FRACTIONS ±	
DECIMALS ±	
ANGLES ±	

AS NOTED

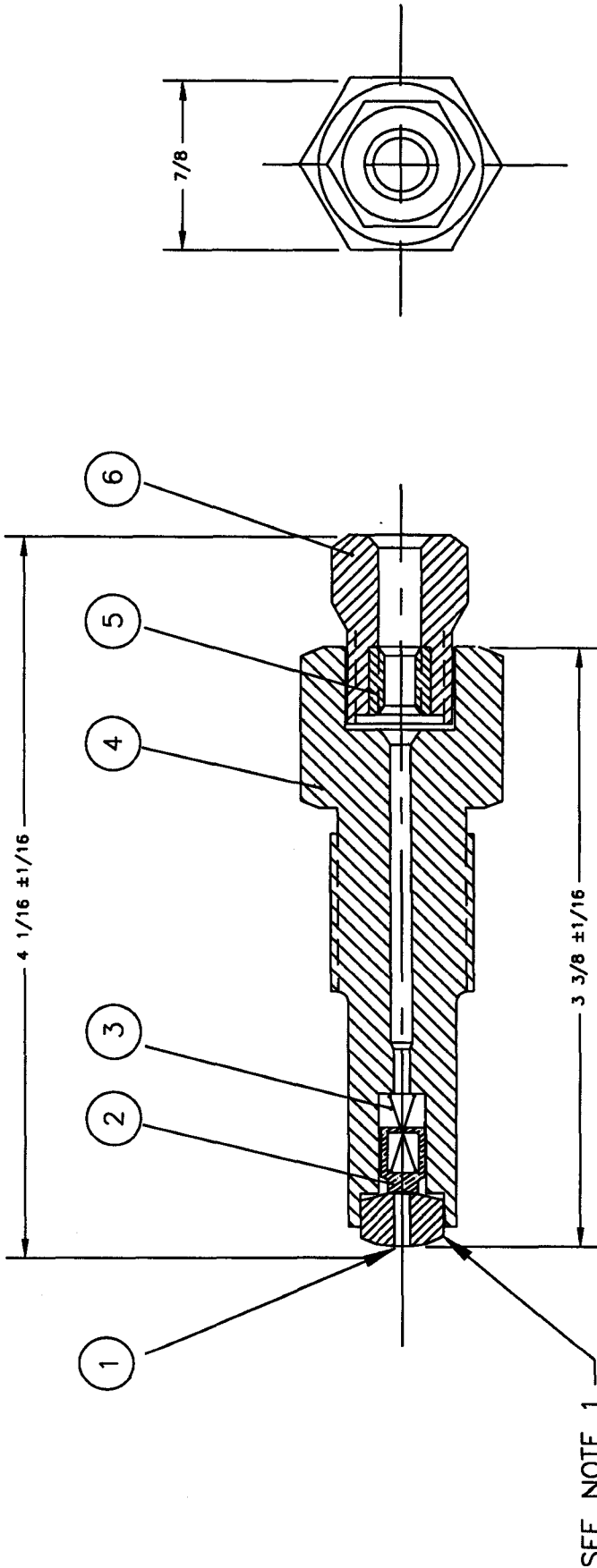

NOTES:

1. STAKE LENS RING OF POPPET; SUB-ASSEMBLY ITEM 1 IN PLACE WITH CENTER PUNCH IF NECESSARY.
2. TIGHTEN GLAND NUT ITEM 6 HAND TIGHT FOR SHIPPING
3. TIGHTEN GLAND NUT ITEM 6 TO A TORQUE OF 15 FT. LBS. APPROX. WITH TUBING INSTALLED.
4. ELECTRO ETCH/MARK
- A. SUPERPRESSURE DIAMOND
- B. CAT NO.
- C. PRESSURE RATING (IF APPLICABLE)
- D. LOT NO. (IF APPLICABLE)
- E. D.O.M.
- F. FLOW ARROW (IF APPLICABLE)

ITEM	QTY.	DESCRIPTION	PART NO.	MATERIAL
6	1	GLAND NUT	45-11313	TYPE 416 ST. STL.
5	1	INNER SLEEVE	45-11316	TYPE 416 ST. STL.
4	1	VALVE BODY	63033000500	TYPE 316 ST. STL.
3	1	SPRING	62005000400	TYPE 302 ST. STL.
2	1	POPPET	62005000200	TYPE 416 ST. STL.
1	1	LENS RING (VALVE SEAT)	63033000300	TYPE 17-4PH

LIST OF MATERIAL

UNLESS OTHERWISE SPECIFIED DIMENSIONS ARE IN INCHES TOLERANCES:		PROPRIETARY	
FRACTIONS ±		This document is issued in strict confidence. No part of it is to be copied, reprinted, or disclosed to a third party, wholly or in part, without written consent of Newport Scientific Inc.	
DECIMALS ±			
ANGLES ±			
REMOVE ALL BURRS AND SHARP EDGES		GAS SERVICE	
DO NOT SCALE THIS DRAWING		CHECK VALVE 30,000 PSI DISCHARGE	
BY		HARD SEAT	
NAME	DATE	CODE DEPT. NO.	SIZE
PREPARED		59505	
CHECKED			
DESIGNED			
APPROVED			
MATERIAL			
AS NOTED		SCALE	WEIGHT
			SHEET OF

ELECTRO ETCH/MARK

- A. SUPERPRESSURE DIAMOND
- B. CAT NO.
- C. PRESSURE RATING (IF APPLICABLE)
- D. LOT NO. (IF APPLICABLE)
- E. D.O.M.
- F. FLOW ARROW (IF APPLICABLE)

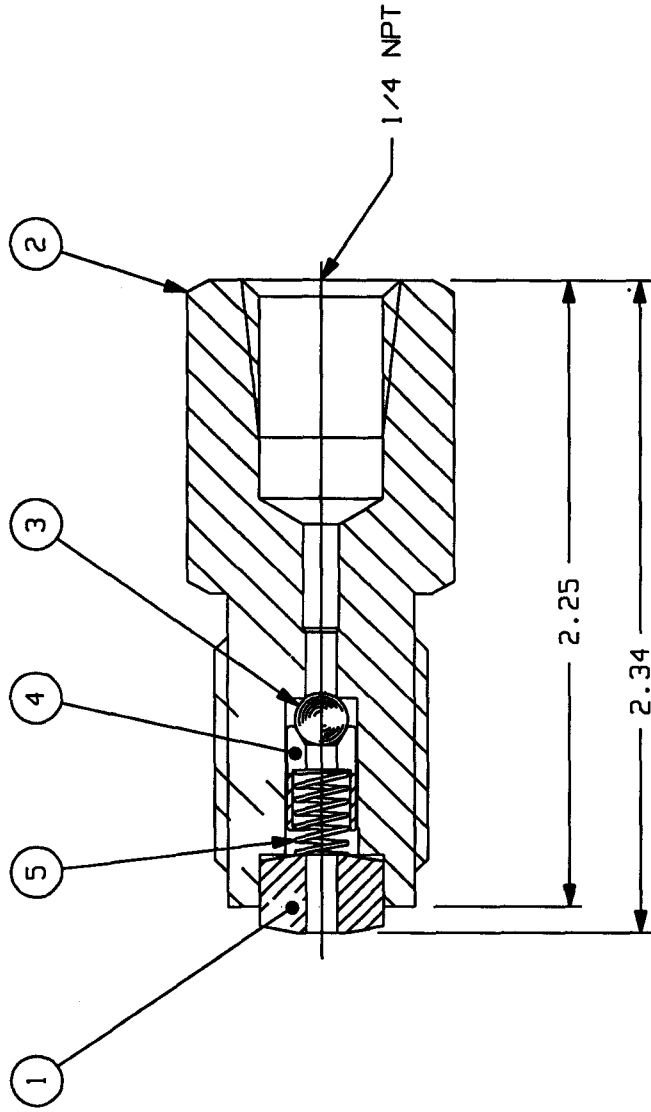
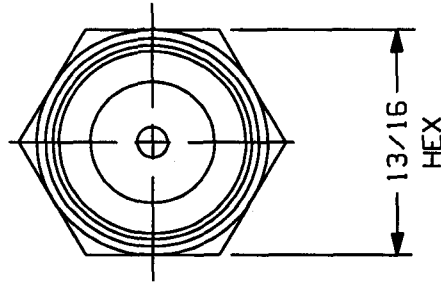

ITEM	QTY	DESCRIPTION	DWG/PART NO.	MATERIAL
5	1	SPRING	50029003204	TYPE 18-8 STAINLESS STEEL
4	1	BALL RETAINER	62002000400	TYPE 316 STAINLESS STEEL
3	1	BALL	P1500013300	TYPE 440 STAINLESS STEEL
2	1	BODY	62079000400	TYPE 316 STAINLESS STEEL
1	1	LENS RING	63038000400	TYPE 17-4PH STAINLESS STEEL
			DWG/PART NO.	MATERIAL

LIST OF MATERIAL

PROPRIETARY

This document is issued in strict confidence on condition that it is not copied, reprinted, or disclosed to a third party, wholly or in part, without written consent of Newport Scientific Inc.

NOTES:

1. STRIKE ITEM 1 (LENS RING) IN PLACE WITH A CENTER PUNCH IF NECESSARY.
2. DIMENSIONS SHOWN ARE FOR REFERENCE ONLY

<p>UNLESS OTHERWISE SPECIFIED DIMENSIONS ARE IN INCHES</p> <p>FRACTIONS ± SEE DECIMALS ± NOTES</p> <p>ANGLES ± REMOVE ALL BURS AND SHARP EDGES</p> <p>DO NOT SCALE THIS DRAWING MATERIAL</p>		<p>CONTRACT</p>		
		<p>BY</p>	<p>NAME</p>	<p>DATE</p>
		<p>PREPARED</p>		
		<p>CHECKED</p>		
		<p>ENGR/DSON</p>		
		<p>APPROVED</p>		
		<p>CERTIFICATION</p>		
		<p>SEE MATERIAL LIST</p>		
<p>NEXT ASSY.</p>	<p>USED ON</p>			
<p>APPLICATION</p>				



NEWPORT SCIENTIFIC INC.

LIQUID SERVICE CHECK VALVE 40,000 PSI INTAKE

<p>CODE IDENT. NO.</p>	<p>SIZE</p>	<p>PART NO. 44-14110</p>
<p>59505</p>		<p>DRAWING NO. 4414110</p>
<p>SCALE</p>	<p>WEIGHT</p>	<p>SHEET 1 OF 1</p>

REVISIONS

SYM	DESCRIPTION	DATE	APPROVED
A	ADDED ITEM #10	10-2-01	

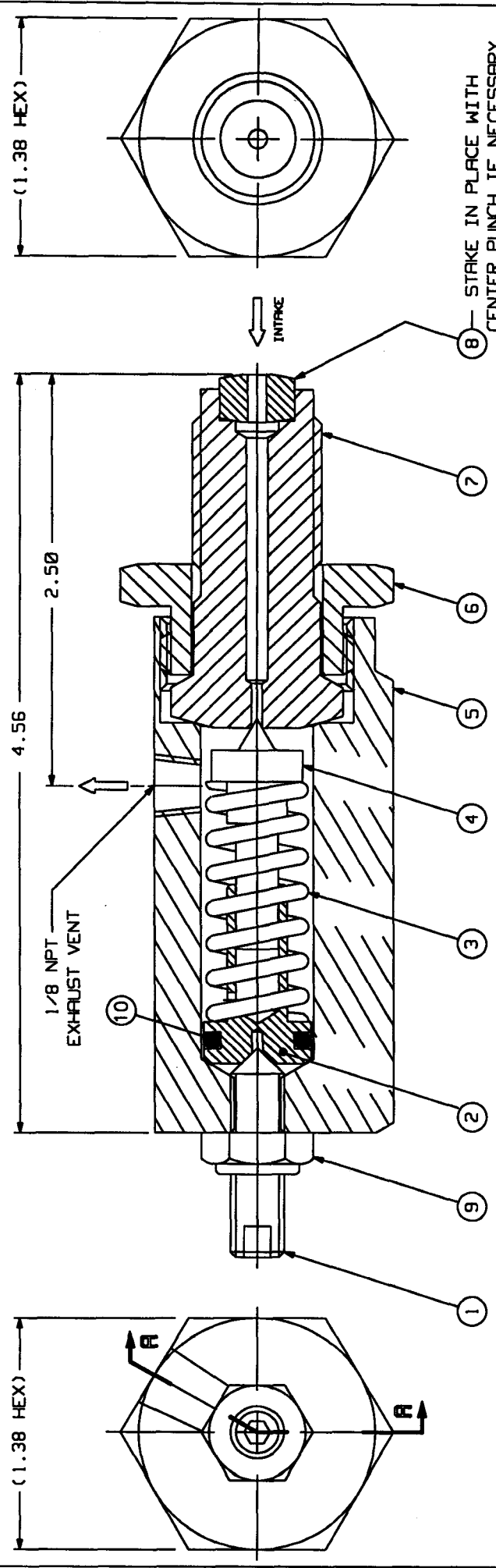

STAMP PART NO.
AND D.O.M.

SECTION R-R

DASH NO.	ORIFICE DIA	PRESSURE RANGE (PSI)
-4	.125	3,000 - 7,500
-3	.046	20,000 - 50,000
-2	.062	14,000 - 35,000
-1	.093	5,000 - 14,000

REPLACES
DRAWING NO.
B1-62006

ITEM QTY	DESCRIPTION	DWG/PART NO.	MATERIAL
10	1 "O" RING	P1604025100	BUNA "N" STEEL
9	1 STOP NUT, THIN ELASTIC, 5/16-24UNF-2B	P1054005500	STEEL
8	1 GASKET, LENS RING	63038000400	17-4 PH STEEL
7	1 VALVE SEAT (SEE CHART)	62006001000	17-4 PH STEEL
6	1 NUT	62006001100	CRS
5	1 BODY	62006000900	CRS
4	1 STEM	64079000200	440C STAINLESS STEEL
3	1 SPRING	P1632014900	ALLOY STEEL
2	1 GUIDE, SPRING	64079000300	416 STAINLESS STEEL
1	1 SET SCREW, SOCKET HD, 5/16-24UNF-2A	62006000800	STEEL

LIST OF MATERIAL

UNLESS OTHERWISE SPECIFIED DIMENSIONS ARE IN INCHES TOLERANCES:
FRACTIONS ±
DECIMALS ± .03
ANGLES ±
REMOVE ALL BURRS AND SHARP EDGES
DO NOT SCALE THIS DRAWING

BY	NAME	DATE	FINISH:
PREPARED			
CHECKED			
ENG/RSK			
APPROVED			

TITLE
RELIEF VALVE FOR LIQUID SERVICE

CODE DWT. NO. 59505
SIZE D
PART NO. 62006001200
DRAWING NO. 1262006

SCALE 2=1
SHEET 1 OF 1

PROPRIETARY
This document is issued in strict confidence on condition that it is not copied, reprinted, or disseminated to a third party, wholly or in part, without written consent of Newport Scientific, Inc.



NEXT ASSY	USED ON	APPLICATION

SEE CHART

SYN	REVISIONS	DESCRIPTION	DATE	APPROVED
④	REDRAWN PER E.C.D. 18695		1/23/87	
⑤	ADD MATERIAL LIST		10/18/89	
⑥	DRILL INFORMATION CHANGE FROM ROSAN TO KEYLOCK INSERT		9/9/01	
⑦	ADDED ITEM 15, KEYLOCK THREAD INSERT		9/9/01	

⑦ .453 DIA. DRILL x 3/4 DEEP MIN TAP 1/2-13 x 5/8 DEEP SPACED ON 4 3/4 B.C. AS SHOWN 6 PLACES

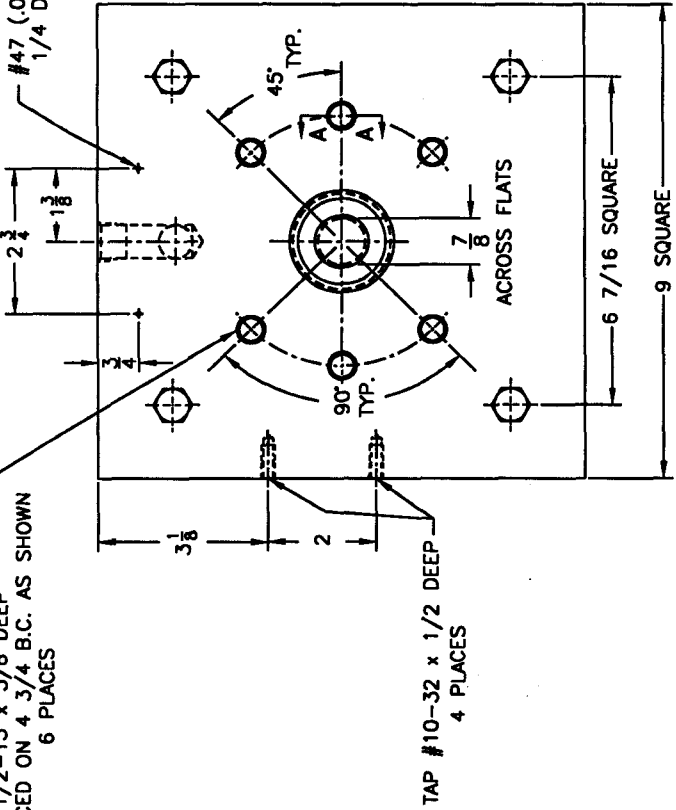
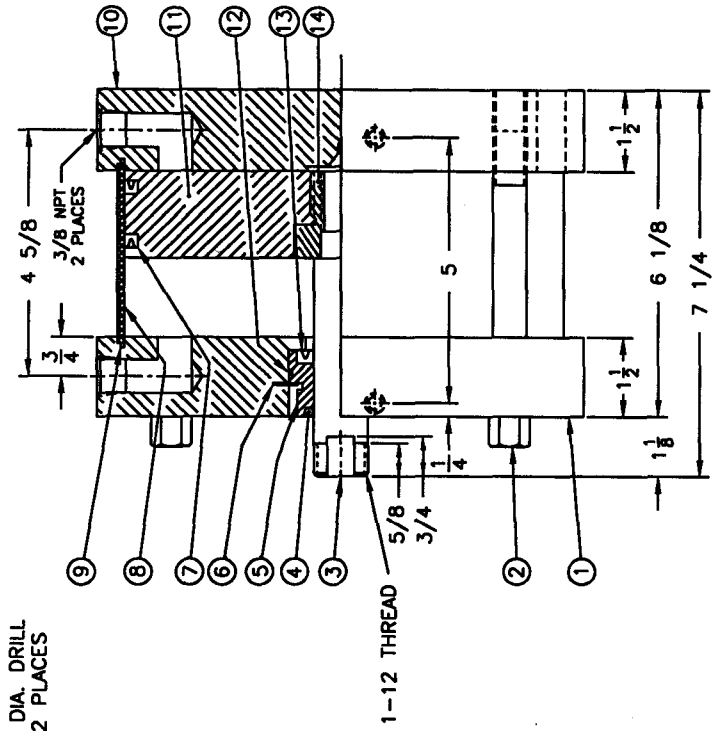

+ .000 CLEARANCE
- .005 ALLOWANCE

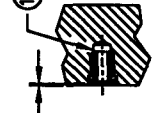

⑮ KEYLOCK THREAD INSERT
6 REQUIRED

WITH ROSAN INSERTS
INSTALLED

SECTION A-A

- NOTES:
1. TUBING IS HARD ANODIZED ALUMINUM.
 2. PISTON AND ROD SEALS ARE BUNA 'N'.
 3. ROD RETAINER IS ELASTUF A2
 4. PISTON ROD IS 17-4PH

ITEM	QTY	DESCRIPTION	DWG/PART NO.
15	6	KEYLOCK THREAD INSERT	P1811002000
14	1	INSERT	77053004500
13	1	SEAL, ROD (S-67-16)	P1825003100
12	1	RETAINER D-RING (S-69-16)	P1825002700
11	1	PISTON	77053004400
10	1	PLATE, BOTTOM	77053004300
9	2	SEAL, CYLINDER (S-99-16)	P1825002900
8	1	CYLINDER	77053003400
7	2	SEAL, PISTON (S-55-16)	P1825002800
6	1	RETAINER RING	P1620021100
5	1	RETAINER	77053003700
4	1	ROD VIPER (S-68-16)	P1825002600
3	1	ROD, LEFT SIDE	77053004200
2	4	STUD WITH NUT	77053004100
1	1	PLATE, TOP	77053003200
		DESCRIPTION	DWG/PART NO.
LIST OF MATERIALS			

UNLESS OTHERWISE SPECIFIED DIMENSIONS ARE IN INCHES TOLERANCES:

FRACTIONS ±
DECIMALS ±
ANGLES ± 0° -30'

REMOVE ALL BURRS AND SHARP EDGES

DO NOT SCALE THIS DRAWING

BY NAME DATE FINISH:

PREPARED CHECKED ENGR/ROD APPROVED

TITLE
SINGLE END PNEUMATIC DRIVE UNIT, 8 IN. BORE
1 1/2 STROKE

CODE IDENT. NO. S9505

SIZE D

SCALE NONE

WEIGHT

SHEET 1 OF 1

PROPRIETARY
This document is issued in strict confidence on condition that it is not copied, reprinted, or disclosed to a third party, wholly or in part, without written consent of Newport Scientific, Inc.



PART NO. 77053001000
DRAWING NO. 1077053

SEE NOTES

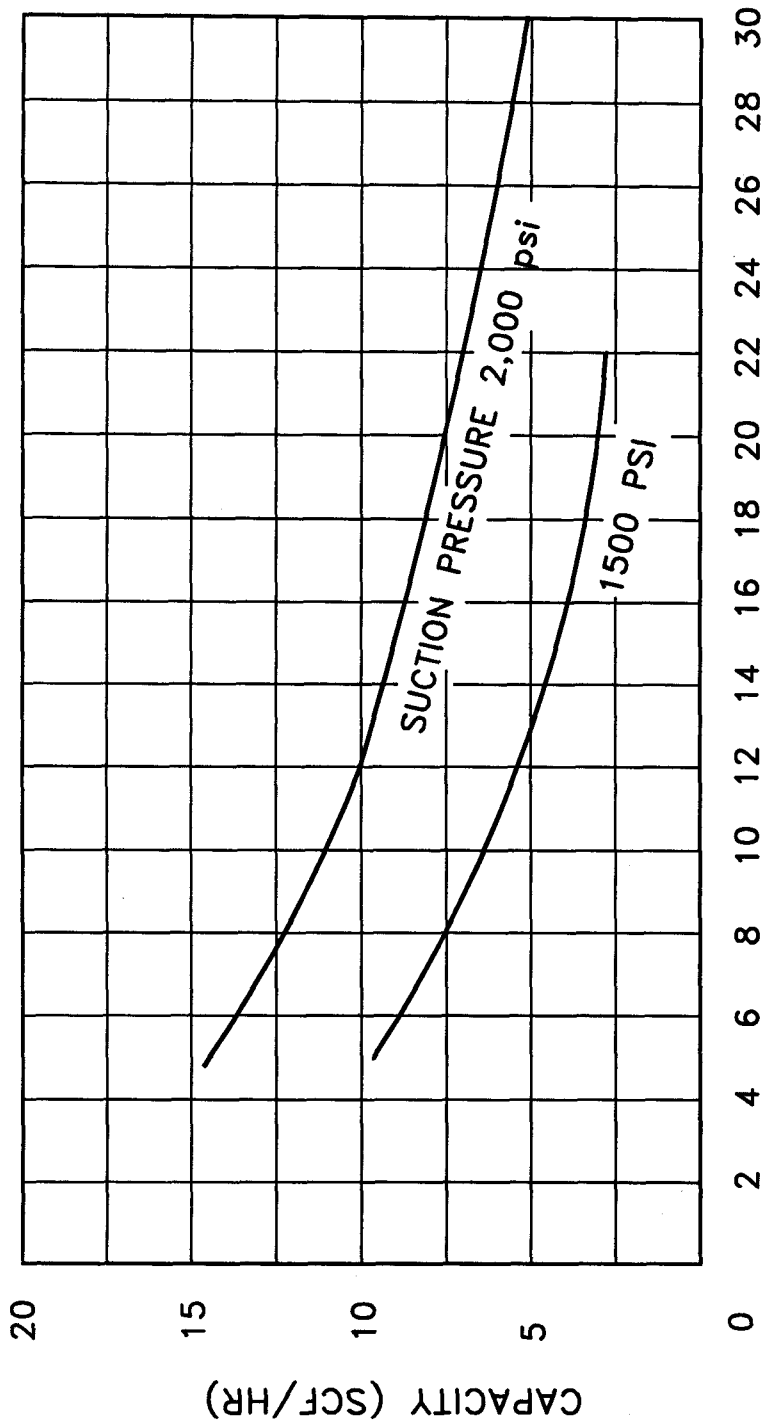

DISCHARGE PRESSURE (x 1000 psi)

TEST DATA

GAS : NITROGEN
 TEMPERATURE : 70°F
 OIL : SAE 20
 AIR DRIVE PRESSURE : 90 PSI NOMINAL

UNLESS OTHERWISE SPECIFIED
 DIMENSIONS ARE IN INCHES
 TOLERANCES:
 FRACTIONS ±
 DECIMALS ±
 ANGLES ±
 REMOVE ALL BURRS AND SHARP EDGES
 DO NOT SCALE THIS DRAWING

PROPRIETARY
 This document is issued in strict confidence on condition that it is not copied, reprinted, or disclosed to a third party, wholly or in part, without written consent of Newport Scientific Inc.

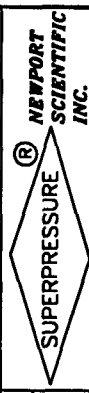

CURVE FOR SINGLE END 30K PSI
 AIR OPERATED #46-14060-2

BY	NAME	DATE	FINISH:
PREPARED			
CHECKED			
ENGR/DSGN			
APPROVED			
MATERIAL			

CODE IDENT. NO.	SIZE	PART NO.	SCALE
59505		CURVE 30K AIR	
		DRAWING NO.	WEIGHT
		CURV30KAIR	

APPLICATION	USED ON